

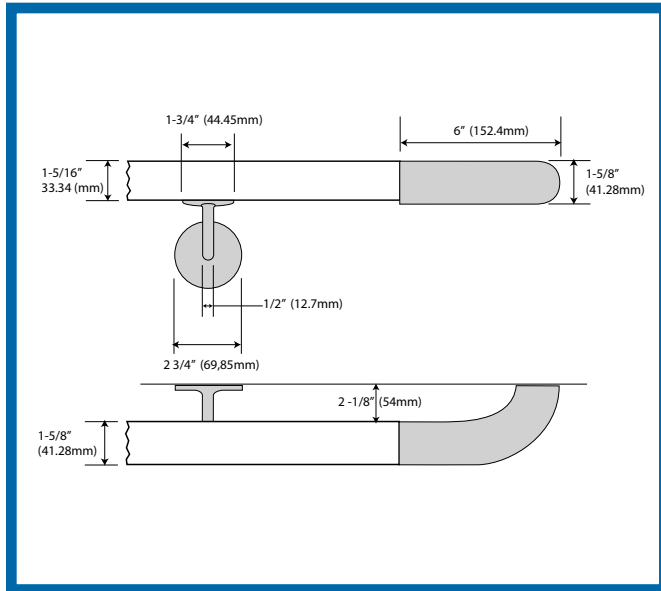

Wood & Stainless Steel Handrail

Models H15-WO, H15-WM



Alpar Architectural's solid wood handrails with stainless steel brackets and returns provide the beauty of hardwood with the strength and durability of stainless steel. Our models combine Forest Stewardship Council (FSC) certified oak (WO) or maple (WM) rails with Type 304 stainless steel brackets and returns. Select a standard clear or colored finish to accent any interior.

About Alpar Architectural Products

Alpar Architectural is a manufacturer of wall protection for use in healthcare, commercial and institutional buildings. All of our products are PVC-free and made from recycled and rapidly renewable materials, including deTerra™ biobased polymer, aluminum and stainless steel. Call for a catalog or visit our website to see our full line of handrails, crash rails, corner guards and sheet wall protection.

Alpar Architectural Products LLC
877-721-0156
612-721-0156
Fax 612-395-9183
info@alpararch.com
www.alpararch.com